

*Please read this complete set of assembly instructions before starting the installation, and only when you understand the construction method, start to follow the step by step guide.*

---

#### Fitting sequence summary:

---

1. Preparing the opening.
  2. Finishing the doors and frame.
  3. Assembling the frame.
  4. Fitting the frame.
  5. Preparing the French doors.
  6. Fitting the door thresholds.
  7. Hanging the doors and fitting the sill threshold.
  8. Fitting the door hardware.
- 

#### 1. Preparing the opening

It is strongly recommended that old doors and windows should not be removed until all the new materials are on site. This avoids the house being open and insecure for a longer period of time than necessary.

The door frame must be fitted under a lintel which extends at least 150mm on to brickwork at both sides of the opening. This must be checked before the opening is prepared and any old frames removed. If an existing lintel is not sufficiently wide, then a new lintel will need to be installed.

##### The T4 external frame dimensions are:

1190mm wide x 2074mm high.

The brickwork opening dimensions should be:

1200mm wide x 2080mm high.

##### The T5 external frame dimensions are:

1490mm wide x 2074mm high.

The brickwork opening dimensions should be:

1500mm wide x 2080mm high.

##### The T6 external frame dimensions are:

1790mm wide x 2074mm high.

The brickwork opening dimensions should be:

1800mm wide x 2080mm high.

The brickwork opening dimensions are slightly larger than the external frame dimensions to allow for square fixing of the frame.

A clean and square opening must be prepared. Any wall cavity, which has been opened, must be closed, incorporating a damp proof course. Check that a damp-proof course is in place at sill level. If not one will need to be installed.

#### 2. Finishing the door and frame.

Before the frame and doors are fitted, all components must be stained in accordance with the finishing instructions.

All timber surfaces on the frame and doors must be given a total of three coats of high performance wood-stain. It is important to apply the treatment to the doors and frame before they are installed.

Failure to treat all the timber surfaces before installation may lead to excessive changes in moisture content which will cause the timber to shrink or swell, perhaps causing splits and distortion.

**When applying the stain pay particular attention to sealing the timber end grain on the tops and bottoms of the frame, side and doors and the ends of the sill.**

Also ensure that the lock and hinge cut outs are stained the same as the timber surfaces, and in particular the undersides (unseen faces).

#### 3. Assembling the frame

**Decide if your doors are to open in or open out.**

Assemble the frame as in **Diagram 1** if the doors are to **open inwards**.

Assemble the frame as in **Diagram 2** if the doors are to **open outwards**.

Use a waterproof adhesive on all the joints and screw the head and sill to the jambs using No.10 x 75mm countersunk screws (supplied) through the pre-drilled holes. Do not fit the drip and in-fill bead at this stage.

The frame must be assembled perfectly square and remain square throughout the rest of the installation. Check the frame diagonals, and only when these measure the same the frame is square.

If necessary, cut off the sill horns from both ends of the sill to fit the brick opening.

#### 4. Fitting the frame

Offer the assembled frame into the brick opening. Check that the sill is level.

Check that the jambs are vertical from side to side and from back to front. **Diagram 3.**

Use a plumb bob and line to check that the inside face of the head is vertically aligned with the inside face of the sill at both ends.

## Assembly Instructions

---

Use wooden / plastic wedges above the jambs and as close to the jambs as possible to hold the frame in the correct position. **Diagram 3.**

It is important to ensure that the frame is positioned and fitted in accordance with all the horizontal and vertical frame checks.

Slip wooden / plastic packers into the gap between the frame and the wall ready to take the permanent fixings. Take care not to bend the jambs in the process.

Secure the frame to the brick opening using a suitable size of frame fixer). 8mm x 120mm frame fixers are suitable in most cases.

Drill and countersink a minimum of five 8mm diameter holes into each of the jambs, a maximum of 150mm from the top and bottom corners and equally spaced. **Diagram 3.**

When tightening the screws use wooden / plastic packers to prevent the frame from distorting. Ensure that the screw heads are below the timber surface.

Fit the draught proofing strip into the frame channel. **Diagram 4.** The draught proofing is only fitted after the frame has been fully treated.

Fit the hinge plates into the frame cut-outs as shown in **Diagram 5.** Secure all six hinge plates using the 40mm screws supplied. Ensure the hinge bushes are fitted into the hinge pins.

### 5. Preparing the French doors.

There are 4 door and frame combinations that can be constructed and these are,

- Option 1** : Opening out, left hand door opening.
- Option 2** : Opening out, right hand door opening.
- Option 3** : Opening in, left hand door opening.
- Option 4** : Opening in, right hand door opening.

**Decide which option you are having and only follow the relevant diagram that relates to your option.**

Fit the draught proofing strips Nos. 1 and 2 into the groove on both door edges as shown in **Diagram 6.**

Ensure that the draught proofing strips are flush to the top and bottom of the doors.

Fit the mullion as shown in **Diagram 6** using the correct option for your build.

Ensure that the mullion is flush to the top and bottom of the fixed door and the cut-outs in the mullion are visible. Secure using the 75mm screw through the pre drilled holes in the mullion.

Fit the draught proofing strip No. 3 into the groove between the fixed door and the mullion as shown in **Diagram 6.** Ensure that the draught proofing strip is flush to the top and bottom of the door.

Lay the opening door in the horizontal position. Refer to **Diagram 7** which shows the correct face uppermost. By measurement, find the middle of the door and with a pencil mark this position. At the centre, mark a line 50mm off from the door edge. Using the template provided align the centre and the door edge line on the template with the marked centre line on the door. Double check the template is positioned correctly. Mark the position of the handle and cylinder lock holes on the opening door as shown in **Diagram 7.** Prepare the holes in the opening door.

Fit the hinge plates into the frame cut-outs as shown in **Diagram 8.** Ensure the plates are fitted the correct way round. Secure all six hinge plates to both the opening and fixed door.

### 6. Fitting the door thresholds

Mark and then cut the door threshold from the correct option shown in **Diagram 9.** Double check before doing any cutting. Secure the door thresholds to the bottom of both the opening and fixed doors using the 19mm screws. **Diagram 9.** Ensure that the uncut end of each of the door thresholds is flush to the hinged edge of the doors. Run a bead of sealant provided along the bottom edge before fitting the thresholds.

### 7. Hanging the doors and fitting the sill threshold

Hang both doors in the frame by lifting each door into position and engaging the frame hinge pins into the hinge plates on the doors. **Diagram 10.** Close the fixed door first and then the opening door to ensure that the doors are positioned correctly in the frame. Check carefully for out of square by closely observing the gap around the doors. If necessary, adjust by using wedges under the sill and above the head of the frame at opposite corners and adjusting the packers at the frame fixers. Check for winding (twist) by observing that the doors close uniformly against the frame weather seals. If necessary, firmly tap the frame (use a block of wood to protect the timber), one corner at a time, until the doors meet the weather seals uniformly. Check that the doors meet correctly in the middle.

Fit the bottom threshold to the top of the sill in the position shown in **Diagram 11** using the correct option. Ensure that the threshold is fitted the correct way round as shown in the diagram. Run a bead of sealant provided on top of the sill before fitting and screwing the bottom thresholds in the correct position.

## 8. Fitting the door hardware

Insert the door bolt into the opening door leaf. **Diagram 12.** Ensure that the top of the door bolt is flush with the top edge of the door, and when in this position that the door bolt lock and spindle holes align with the drilled holes in the door. When this alignment is correct secure the door bolt in place using the 25mm screws, as shown in **Diagram 12.**

**Note:** The door latch may require to be turned around. If required, use a pair of mole grips to pull the latch out and spin it around. Refer to **Diagram 12** for the correct positioning.

Insert the cylinder lock into the opening door bolt and secure using the machine screw as in **Diagram 12.**

Fit the handle set as in **Diagram 12.**

With the door in the open position lift the handle upwards to ensure that the shoots eject properly and the lock hooks operate. Retract the shoots by moving the handle downwards.

Position the latch plate into the rebate in the mullion. Overlay on top the lock keep bar, and with the three centre holes aligning secure the keep bar through the latch plate to the mullion using the 25mm screws as in **Diagram 13.** Ensure that the keep bar is the correct way round as shown in **Diagram 13.** Using the 25mm screws secure the keep bar to the mullion through all the remaining holes.

Insert the top lever action shoot bolt into the top of the mullion ensuring that it is flush with the top of the mullion, and secure in place using the 25mm screws as in **Diagram 13.**

Insert the bottom lever action shoot bolt into the bottom of the mullion so that it overhangs the bottom of the mullion by 7mm, and secure in place using the 25mm screws as in **Diagram 13.**

Position the shoot bolt keep into the sill threshold. With the opening door left open, fully close the fixed door into the frame.

Slide the shoot bolt keep to sit underneath the lever action shoot bolt and eject the bolt to engage into the keep as in **Diagram 14.** Position the keep so that the shoot bolt is sitting in the centre of the keep and mark the position of the keep in the threshold. Retract the shoot bolt and open the fixed door. Secure the shoot bolt keep using the 25mm screws, drilling through the sill threshold first as in **Diagram 14.**

Fit the top shoot bolt keep into the frame head groove, positioning it in the same way using the top lever action shoot bolt as in **Diagram 14.**

Close the fixed door and engage the lever shoot bolts into the frame keeps top and bottom.

There is minor adjustment that can be made on the shoot bolt keeps, which will ensure that all the door shoot bolts engage correctly into the keeps and remove any door rattle.

Close the opening door ensuring that the latch engages correctly into the latch-plate. If the latch is not engaging into the latch-plate, adjustment is made by filing down the hump on the lock keep bar, until the latch snaps into the locking keep bar. **Diagram 13.**

The hump on the slot for the deadbolt may also have to be filed down if the deadbolt does not engage correctly. Lift the door handle upwards to operate the shoot bolts top and bottom ensuring that the shoots engage correctly into the keeps.

The hooks that eject from the door bolt when the handle is lifted upwards will engage into the keep bar fitted to the mullion.

Fit the drip bead into the outside groove of the frame head using 38mm panel pins (supplied). Refer to **Diagram 4.** This will allow the drip bead to be removed in the event that the doors need to be lifted off their hinges.

Fit the internal bead into the inside groove of the frame head using woodworking adhesive. Refer to **Diagram 4.**

**Diagram 1**

Each diagonal must measure equally to ensure frame is square

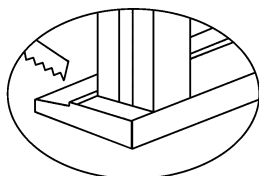
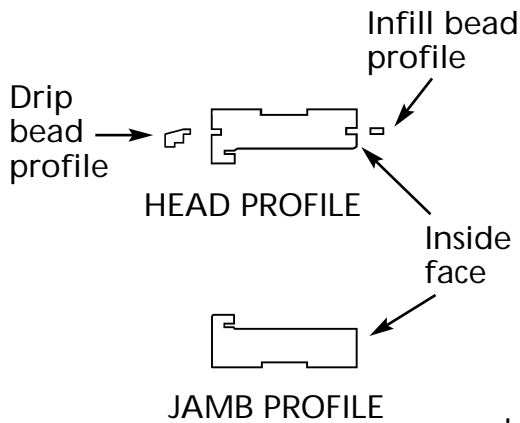
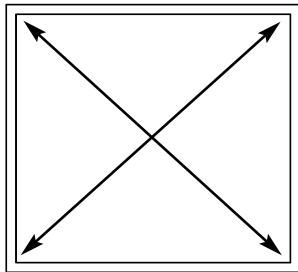

Cut back both ends of the sill flush with the jambs if required

**FRAME ASSEMBLY FOR OPENING IN FRENCH DOORS**

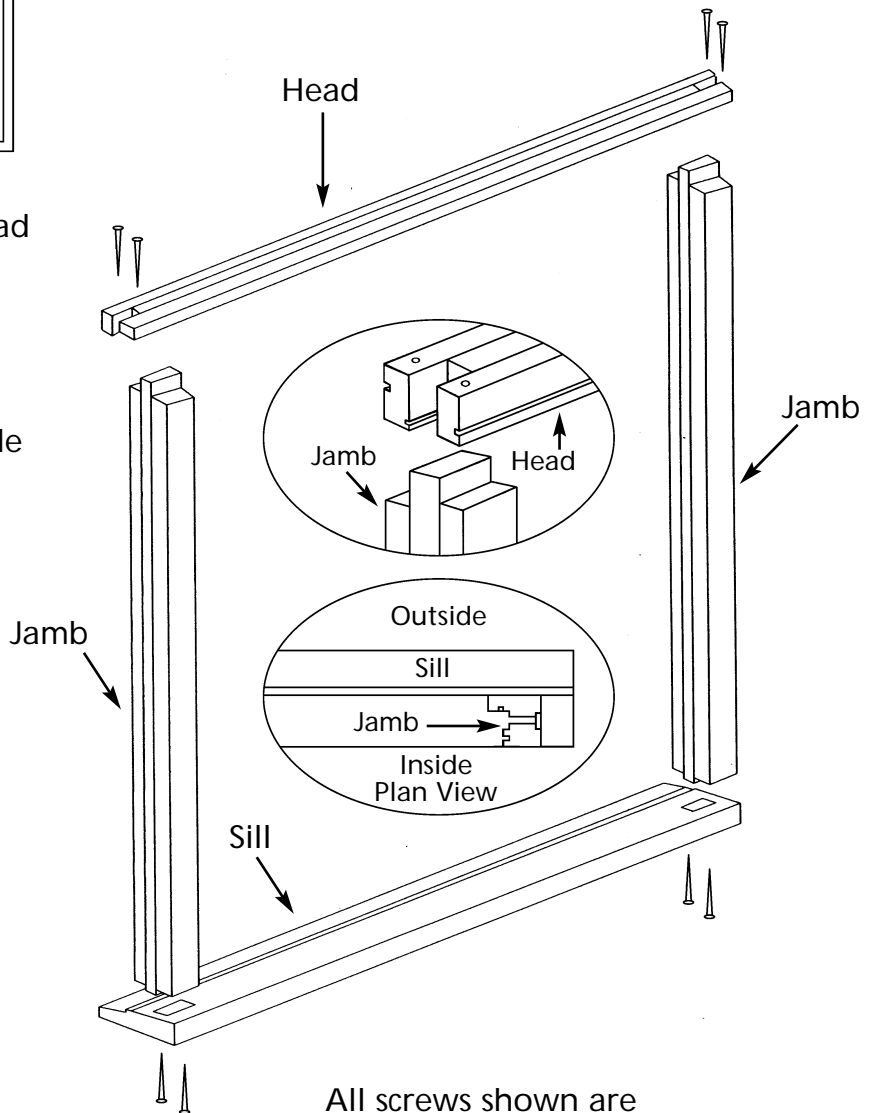

All screws shown are 75mm x No. 10 countersunk

**SECTION 3 : ASSEMBLING THE FRAME**

**Diagram 2**

Each diagonal must measure equally to ensure frame is square

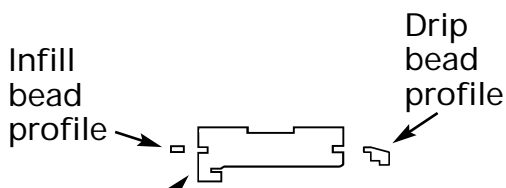
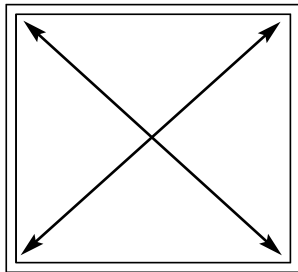

HEAD PROFILE

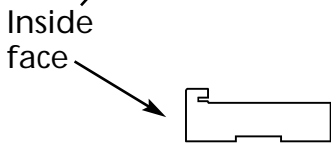

JAMB PROFILE



SILL PROFILE

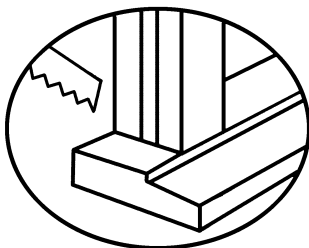

Cut back both ends of the sill flush with the jambs if required

**FRAME ASSEMBLY FOR OPENING OUT FRENCH DOORS**

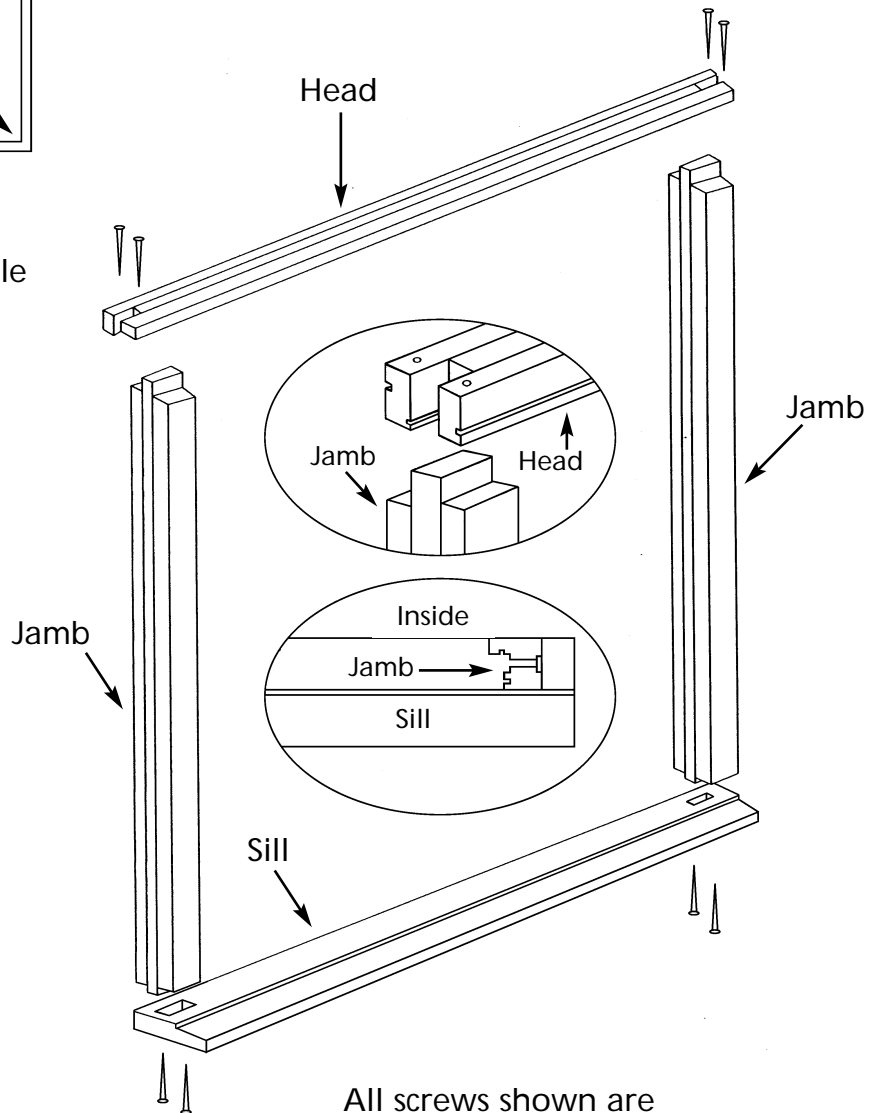

All screws shown are 75mm x No. 10 countersunk

**SECTION 3 : ASSEMBLING THE FRAME**

Diagram 3

Use a spirit level on the face of the jambs and sill to check for plum

- Indicates the frame fixing positions

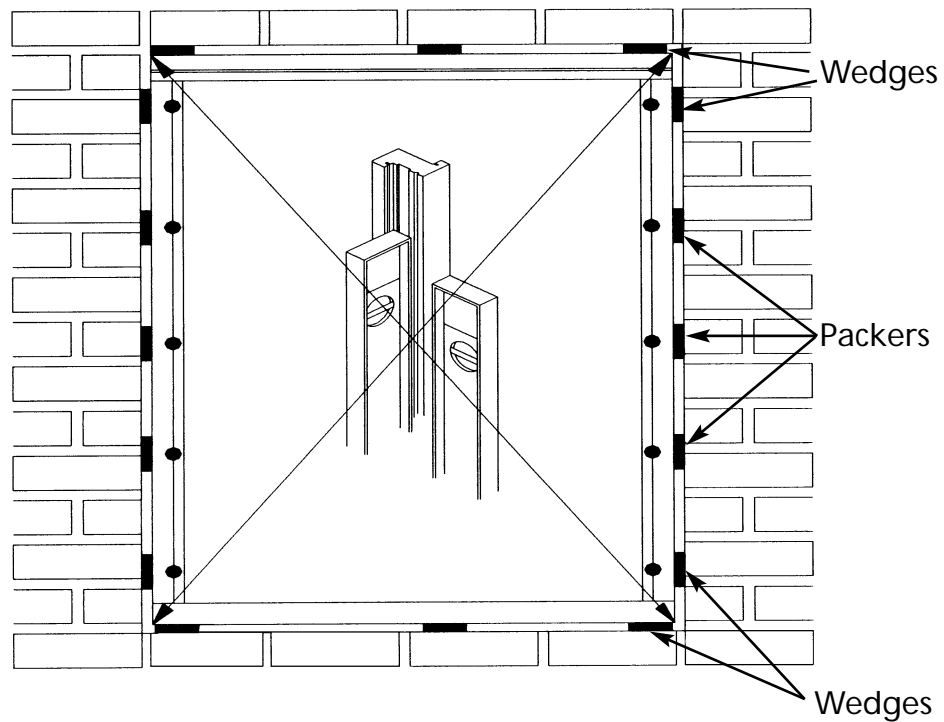

Plan view

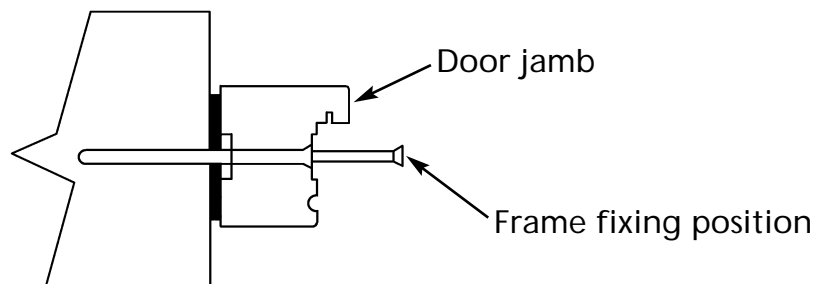

**SECTION 4 : FITTING THE FRAME**

Diagram 4

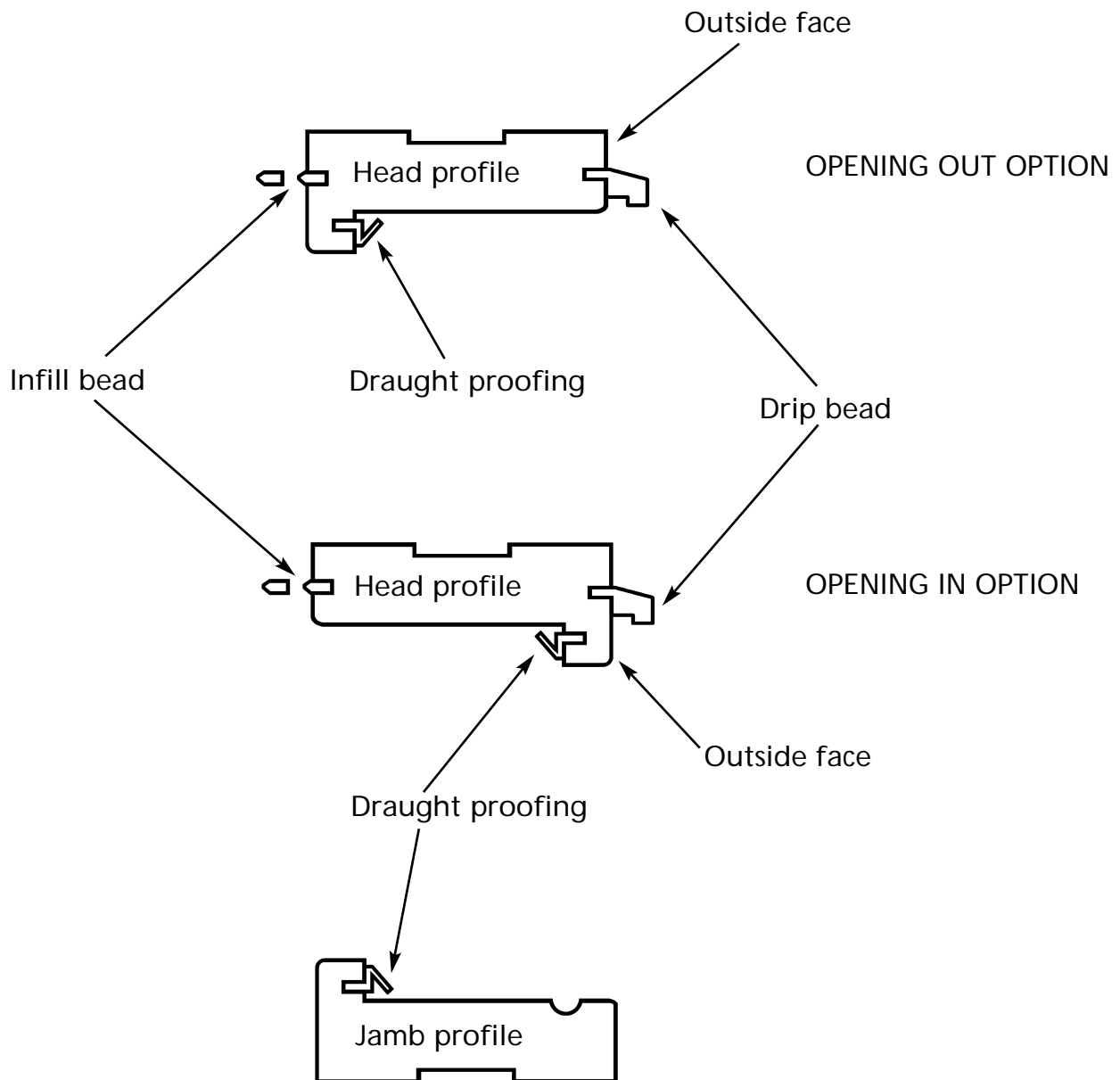

**SECTION 4 : FITTING THE FRAME**

Diagram 5

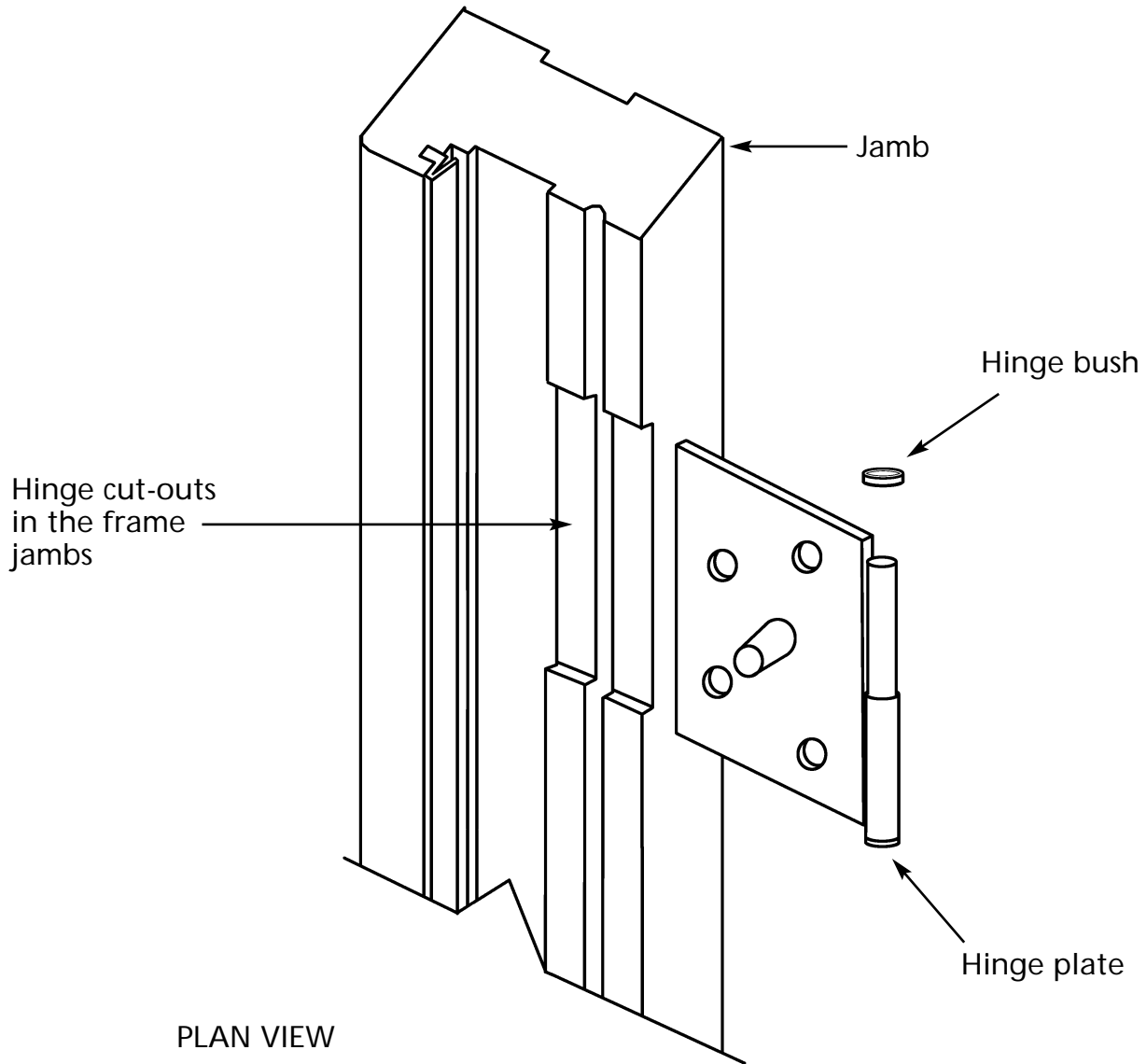

PLAN VIEW

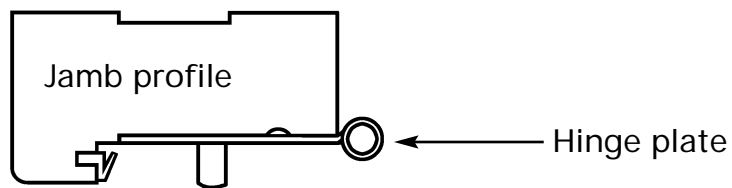

**SECTION 4 : FITTING THE FRAME**

Diagram 6

OPTION 1 : OPENING OUT, LEFT HAND DOOR OPENING

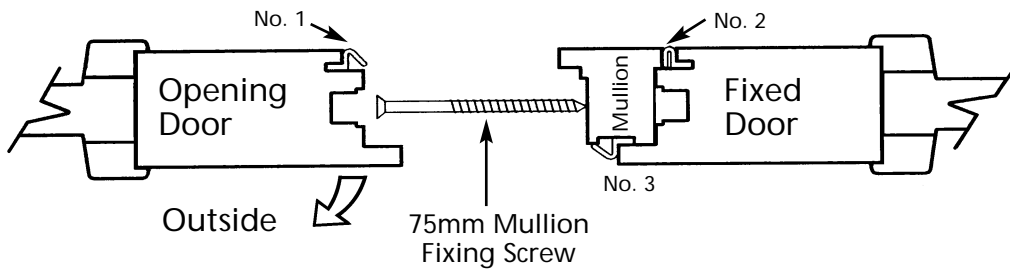

OPTION 2 : OPENING OUT, RIGHT HAND DOOR OPENING

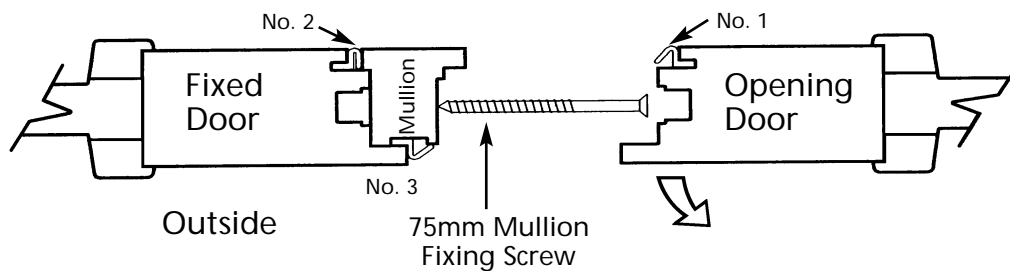

OPTION 1 : OPENING IN, LEFT HAND DOOR OPENING

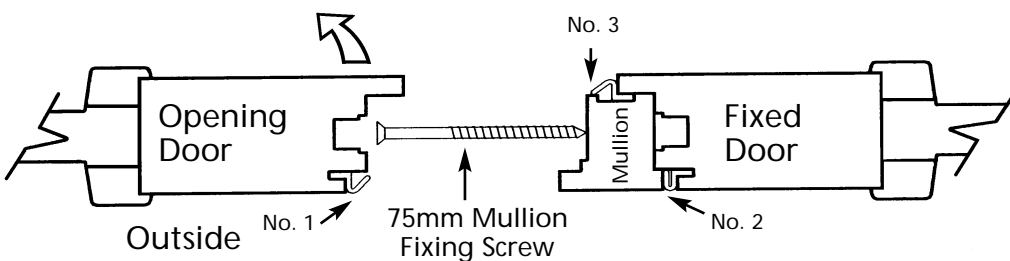

OPTION 1 : OPENING IN, RIGHT HAND DOOR OPENING

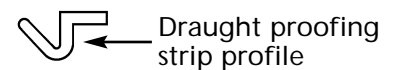
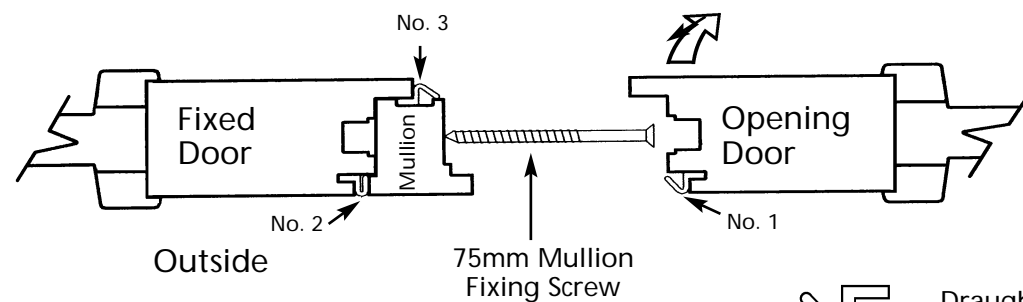

**SECTION 5 : PREPARING THE FRENCH DOORS**

Diagram 7

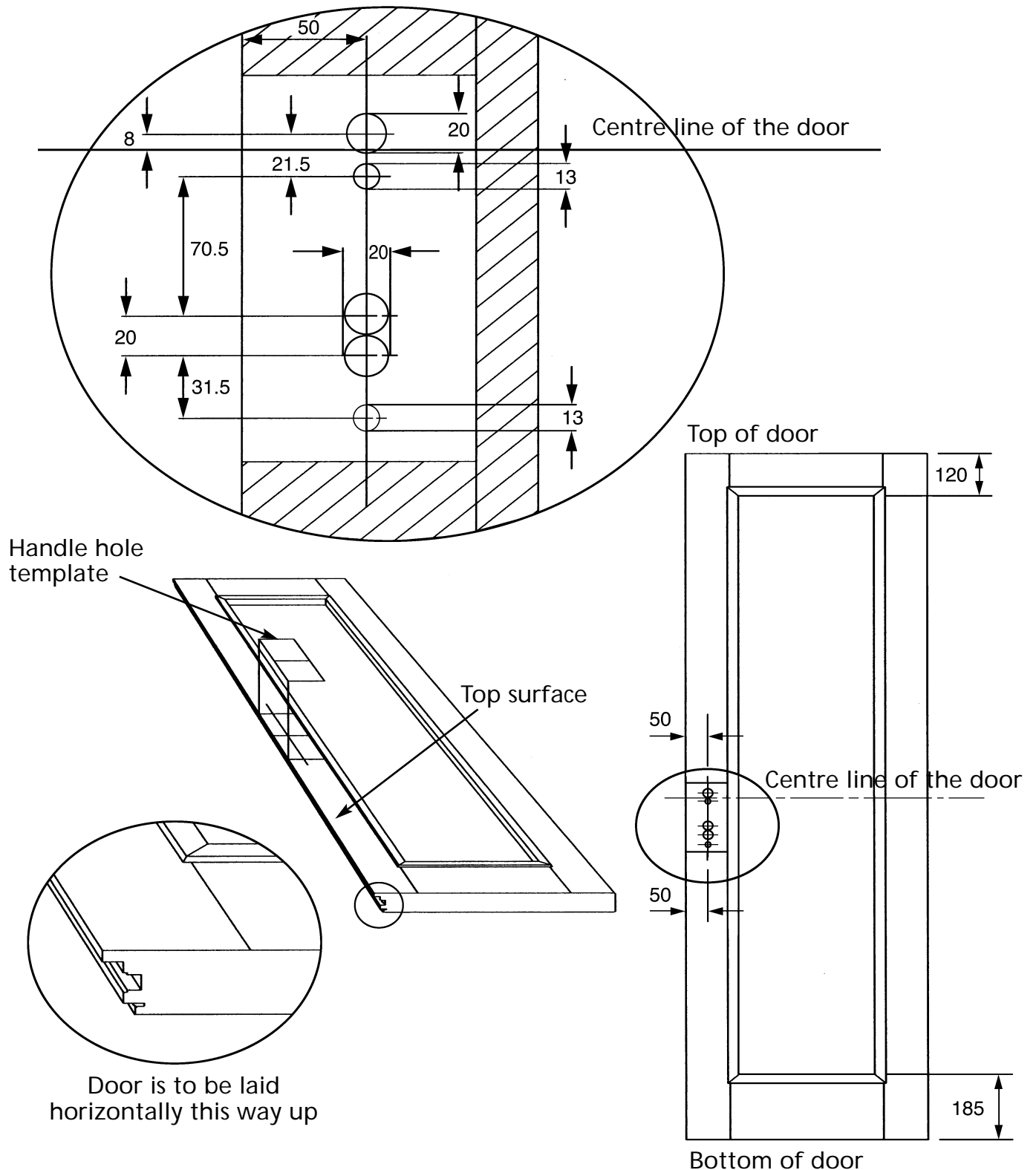

Door is to be laid horizontally this way up

**SECTION 5 : PREPARING THE FRENCH DOORS**

Diagram 8

PLAN VIEW

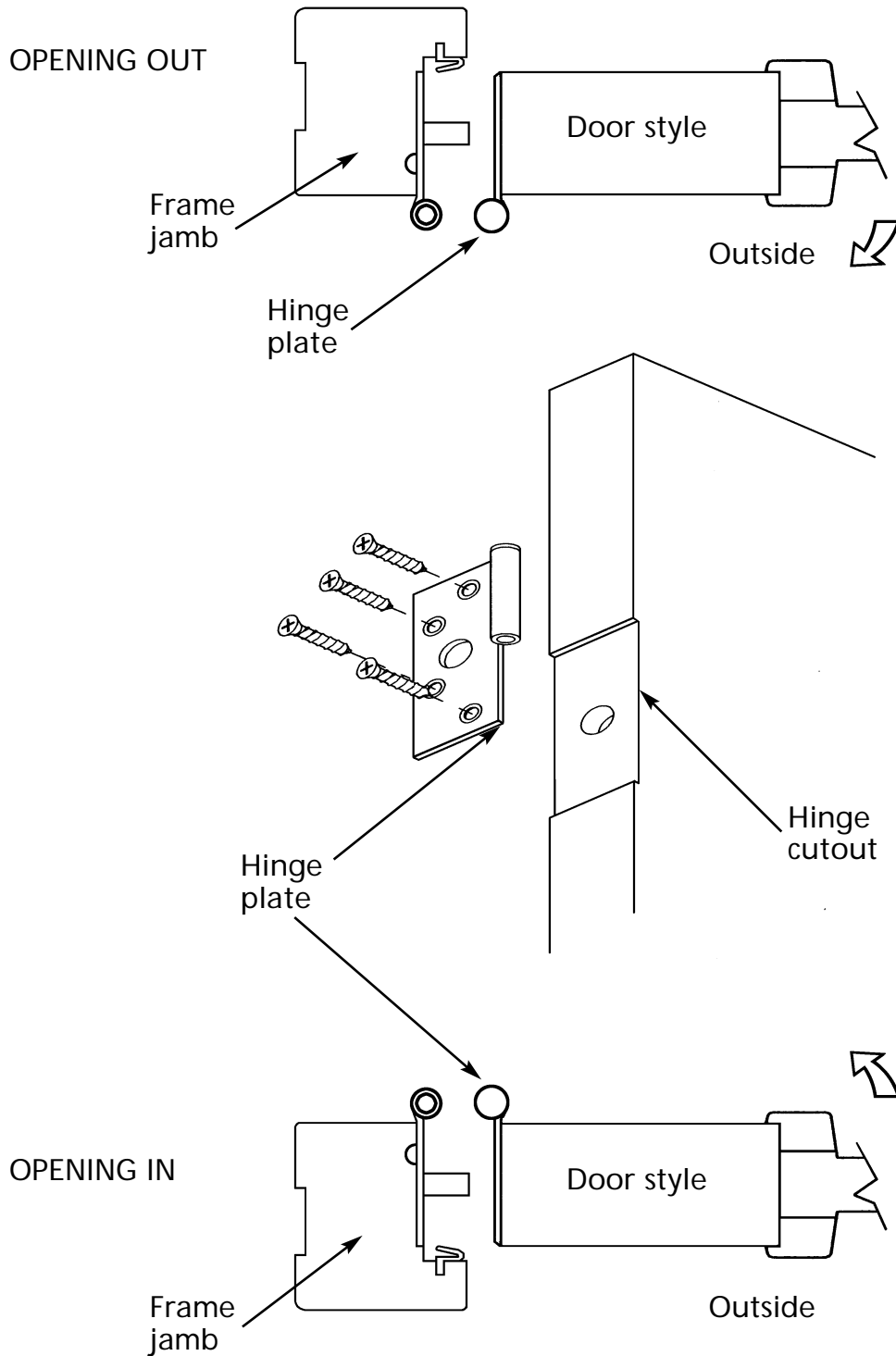

**SECTION 5 : PREPARING THE FRENCH DOORS**

**Diagram 9**

**OPTION 2**  
Plan view opening out, right hand door opening

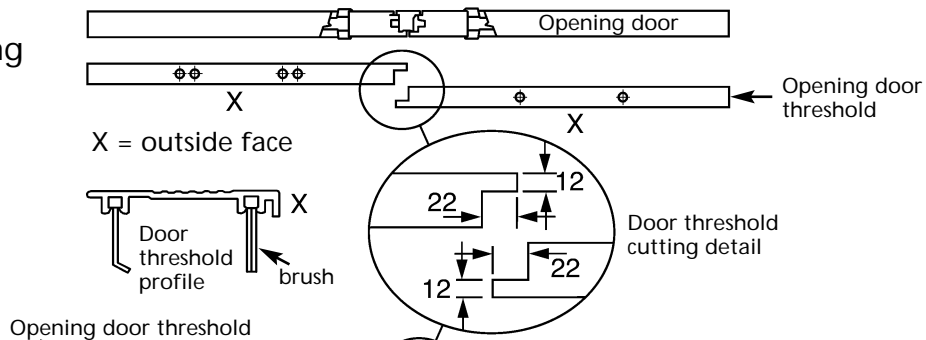

**OPTION 3**  
Plan view opening in, left hand door opening

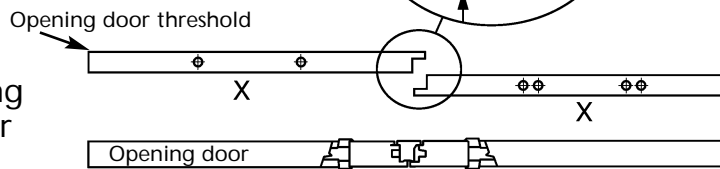

**OPTION 1**  
Plan view opening out, left hand door opening

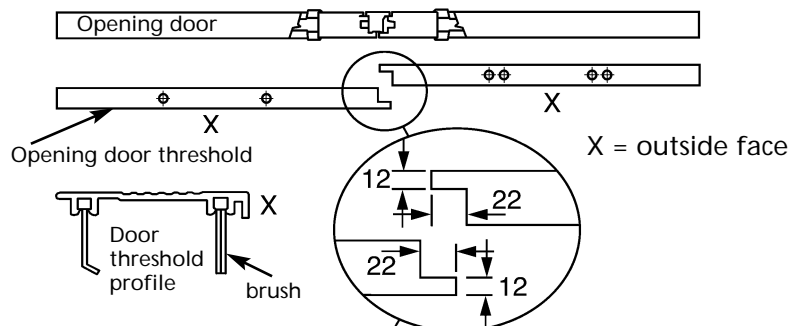

**OPTION 4**  
Plan view opening in, right hand door opening

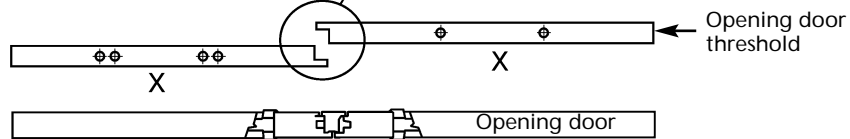

The thresholds are supplied to the correct length. Do not alter the length.

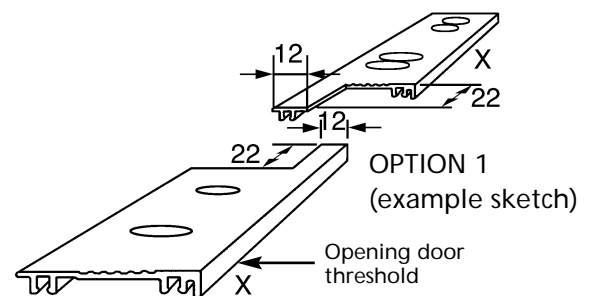
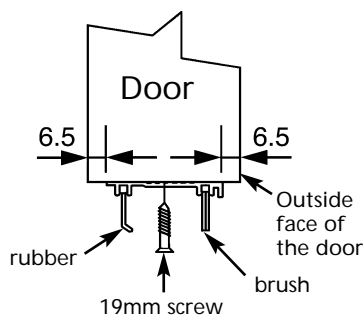

**SECTION 6 : FITTING THE DOOR THRESHOLDS**

Diagram 10

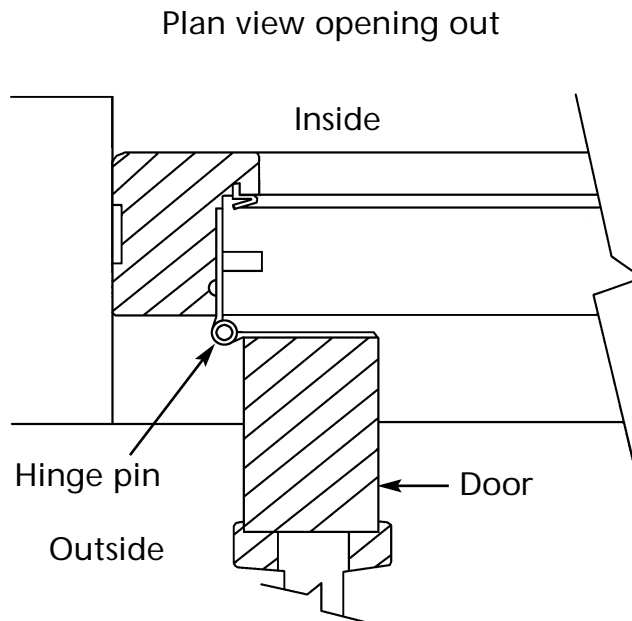
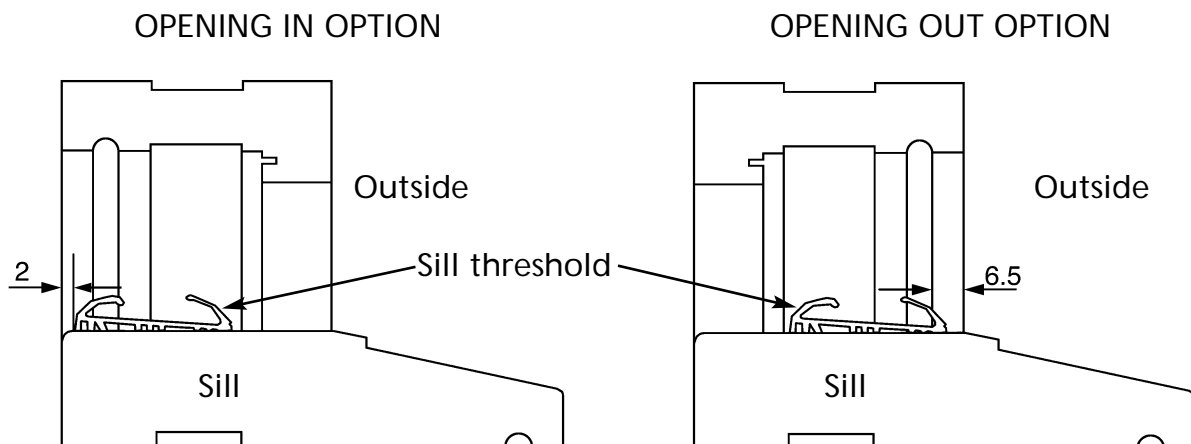
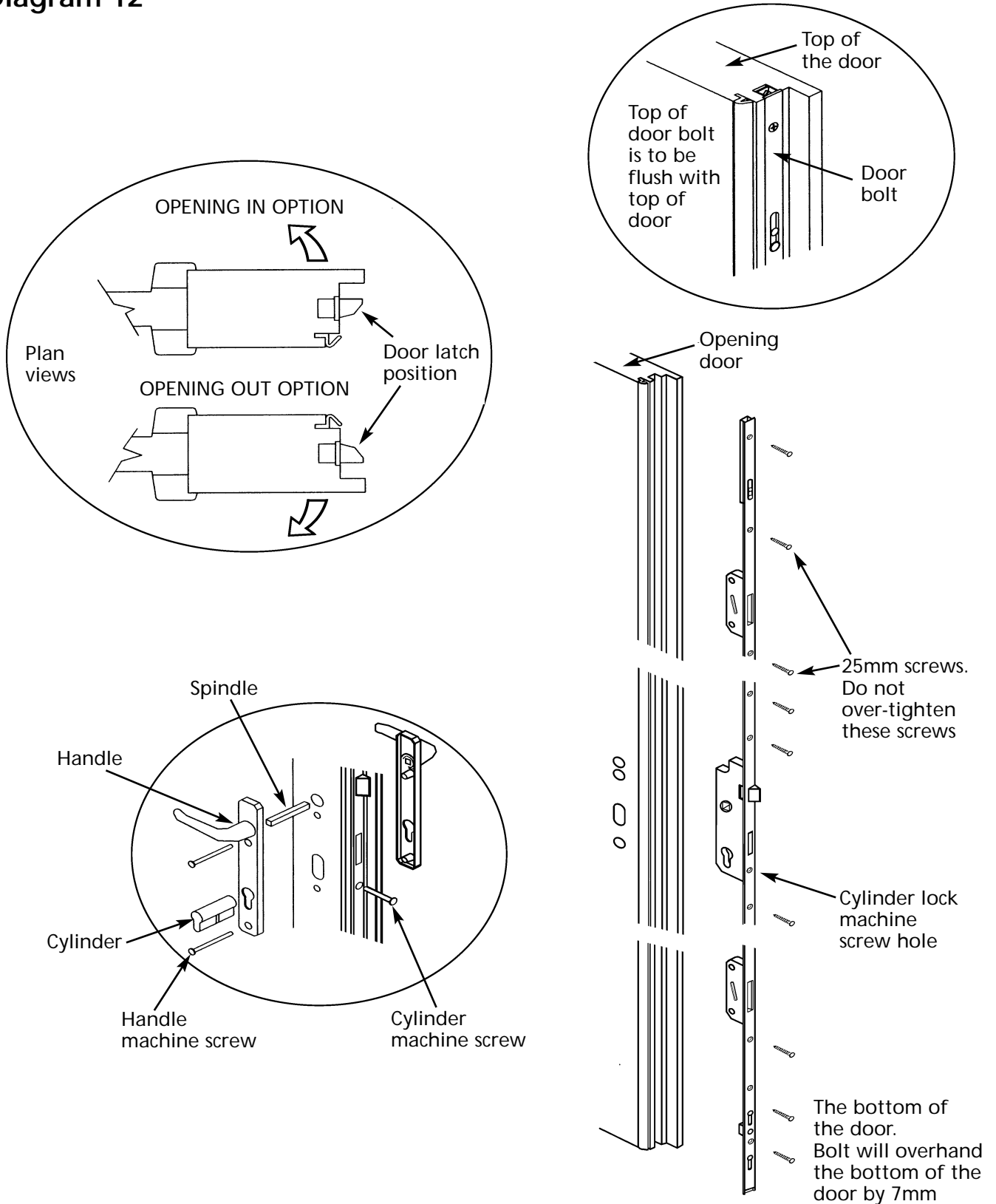

Diagram 11



**SECTION 7 : HANGING THE DOOR AND  
FITTING THE SILL THRESHOLD**

Diagram 12



**SECTION 8 : FITTING THE DOOR HARDWARE**

Diagram 13

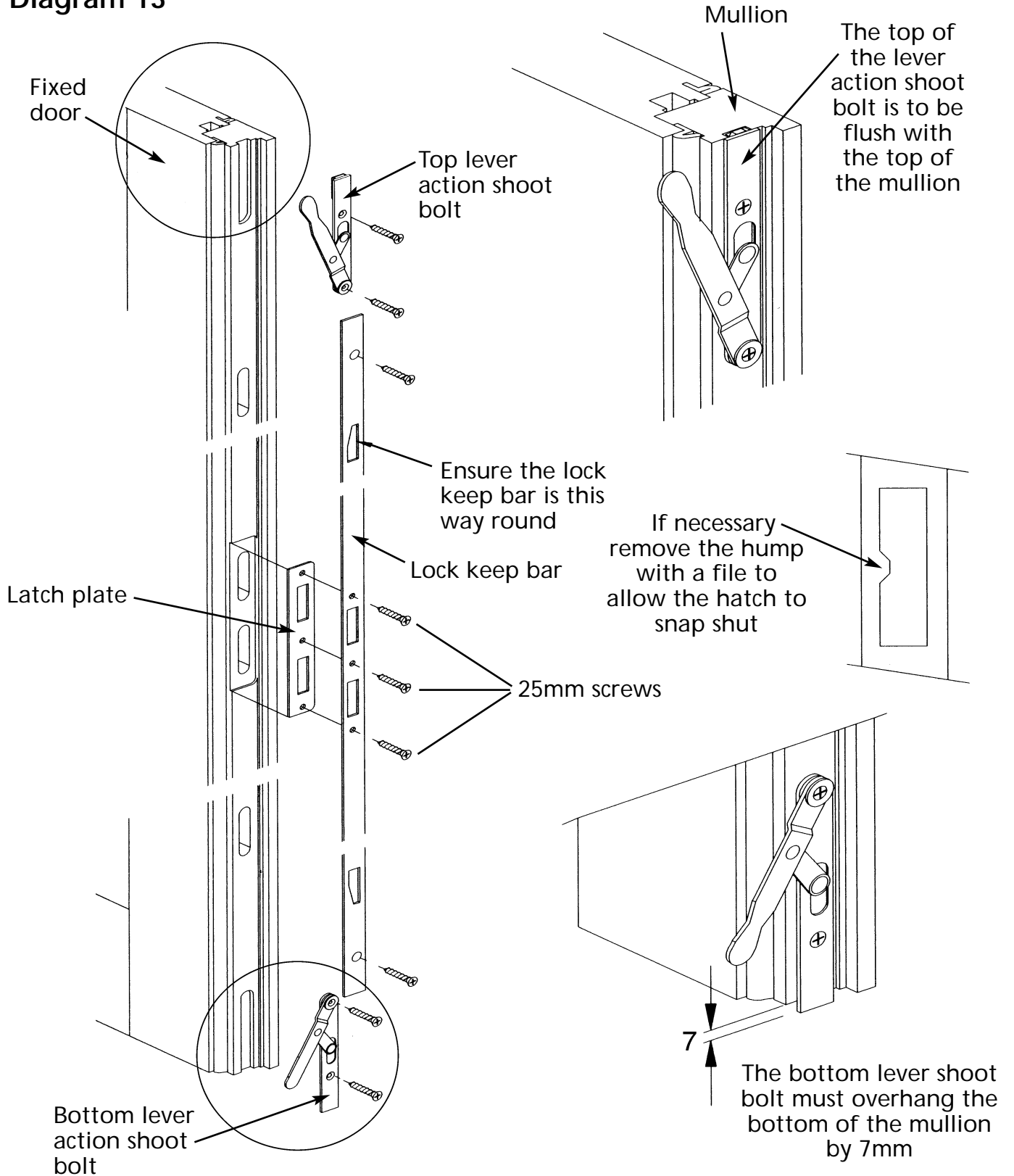

**SECTION 8 : FITTING THE DOOR HARDWARE**

Diagram 14

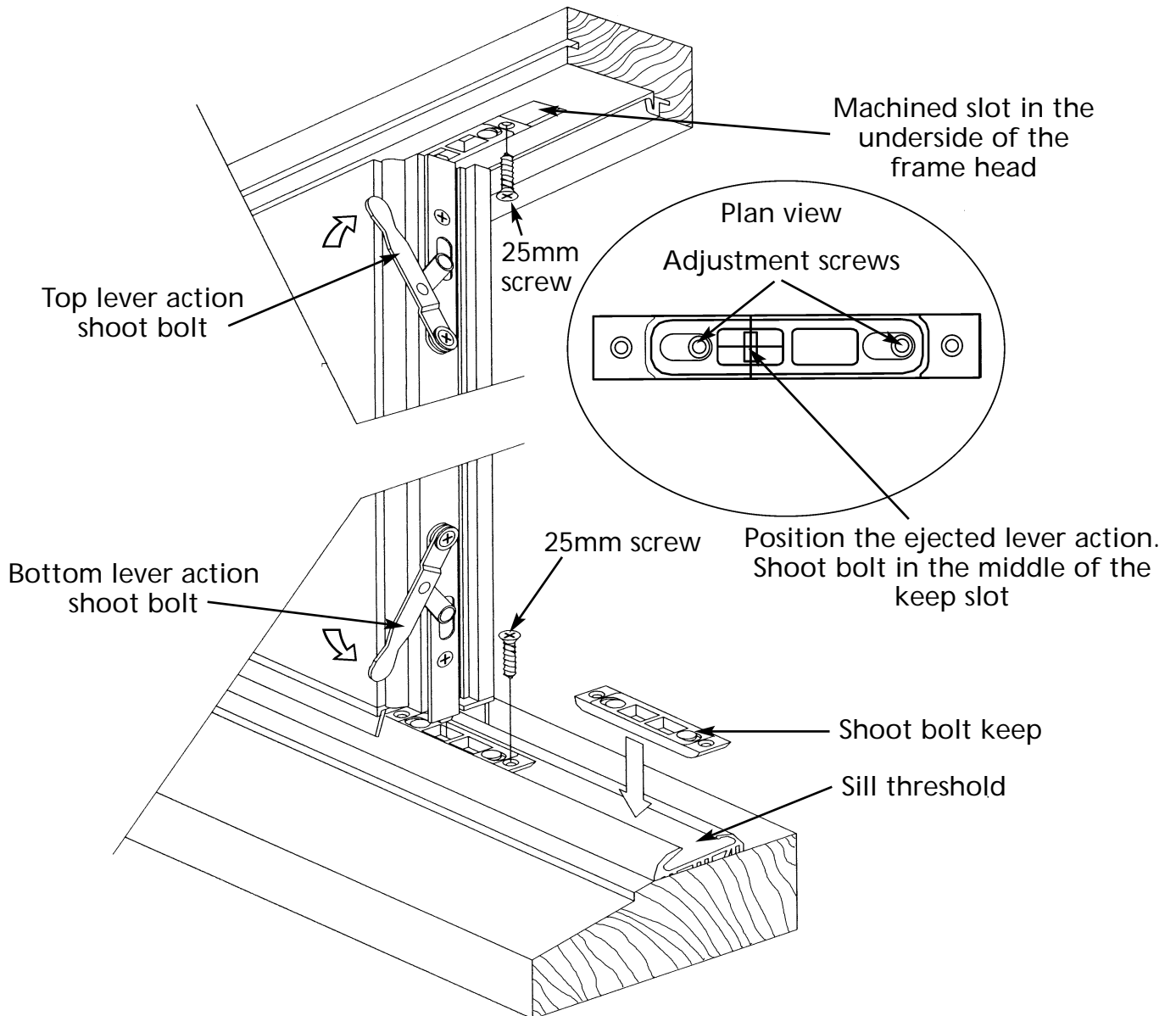

**SECTION 8 : FITTING THE DOOR HARDWARE**

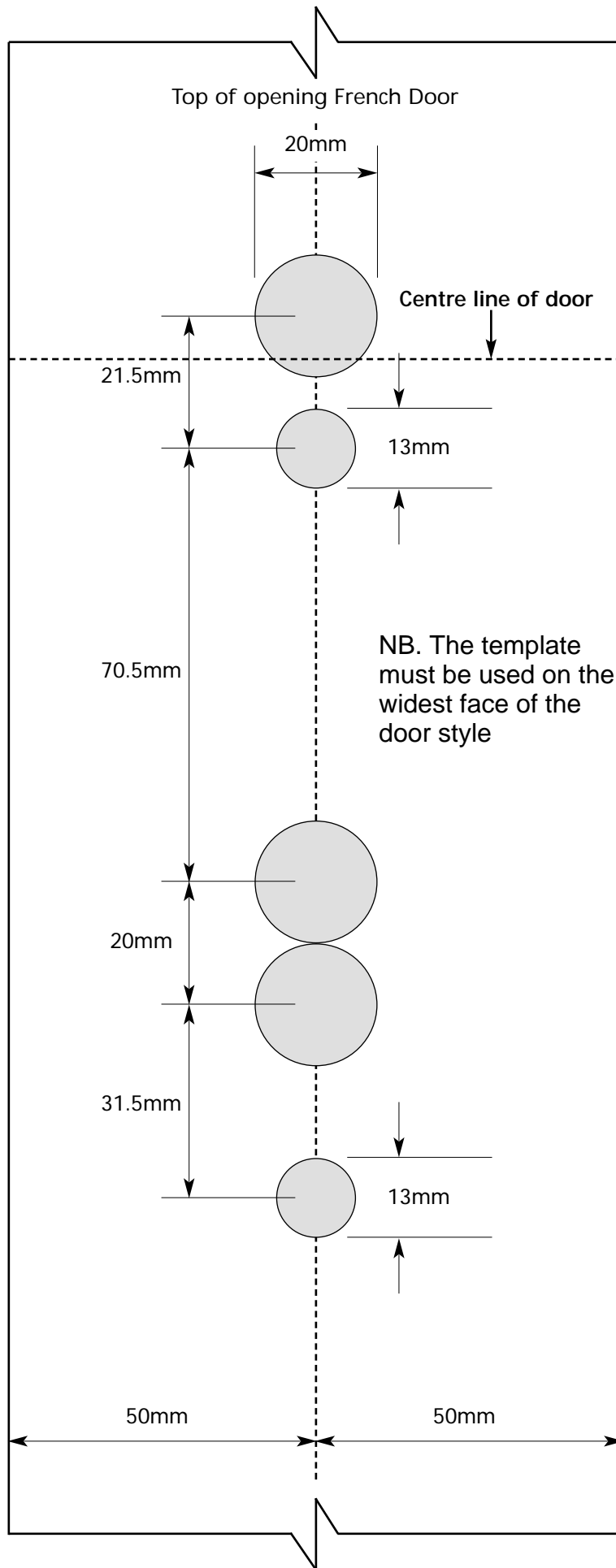

**DOOR HANDLE TEMPLATE**