

### IMPORTANT NOTE



This product needs to be installed by a Competent Tradesperson with assistance.

Two people are required to carry out the installation, as some components are heavy.

The Outer-Frame requires a fixing to the building Lintel over the opening. The Lintel **MUST** be capable of carrying the load of the door in all conditions. If in doubt check with a structural engineer.

For further advice contact:

Tel: 01675 469016

[www.ejoinery.co.uk](http://www.ejoinery.co.uk)

## Fitting and Fixing Guidelines for

Canberra and Wellington Patio Doorsets

### Building Regulations

Please consult with your building designer to ensure compliance with current Building Regulations such as Approved Documents L&F.

Replacing patio doorsets is included under Building control and MUST either be carried out by a FENSA registered installer, or with prior Building Control Approval.

Registered FENSA companies can be found at [www.fensa.co.uk](http://www.fensa.co.uk)

## Section A

### Parts Check List

Your Canberra or Wellington Patio Doorset comes in a ready to assemble state. All the components are packed into four (4) Packs.

These are:

- 1) Doors Pack (All doors are individually packed and labelled)
- 2) Frame Pack (Consist of four sub-assemblies i.e., Head, Sill, Left & Right jambs)
- 3) Door Hardware Pack (Detailed on the "Door and Hardware Arrangement Sheet")
- 4) Frame Fixing Pack (See list below)

Frame Fixing Pack	Canberra	Wellington
24 x 100 2.5 to 1mm Wedge Packer	34	17
24 x 100 1.0mm Flat Packer	68	34
24 x 100 3.0mm Flat Packer	68	34
QThor Tie Bzp	8	5
8 x 100 Fisher Fixings (Jamb Position)	8	10
Brown Plug	8	5
Wood Screws 8g x 1 1/2	16	10
Hex Self Cutting Screw 55mm long	18	-
Bonded Washer G16	18	-
Self-drilling Screw LSCW70CWNW	-	10

The installation instructions MUST accompany two sheets labelled '**Door & Hardware Arrangement Sheet**' and '**Doorset Lintel Specification Guide**'

These sheets are specific to your door set and explain the following:

- 1) Hinge configuration/orientation in the overall doorset assembly.
  - 2) Door panel codes.
  - 3) Door panel configuration with corresponding labels in the overall doorset assembly.
  - 4) All the 'Packs' that are supplied to you and are essential to install the doorset.
  - 5) How to install the Frame in Brickwork Opening.
- If any of the items listed in these sheets are missing, you MUST contact your supplier immediately.

## Section B

### Required Items & Tools

The following tools and items are required to carry out the installation of JELD-WEN Canberra and Wellington Patio Doors.

- ✓ Appropriately long Spirit Level.
- ✓ Masonry Drill.
- ✓ Cordless screw driver.
- ✓ 5 metre Measuring Tape.
- ✓ Appropriate Timber Silicone Sealant (appx. 3 tubes)
- ✓ Mallet.
- ✓ Additional packers for accurate frame installation (frame to structure) if required.

Drill bit 3.5mm dia – 1 x masonry, 1 x steel cutter. Both 125mm minimum length.

## Section C

### Planning the Layout

Before you start the installation, carefully plan the following aspects and understand the assembly of a doorset by thoroughly reading these instructions.

#### 1) Brickwork Opening

The brickwork opening plays a vital role in the installation of the Canberra or Wellington Patio Doorset. Make sure that all the internal surfaces of brickwork opening are 'levelled' before you start the installation.

Figure 1 shows the correct brickwork dimensions for your doorset.

You MUST make sure that the

- Horizontal
- Vertical, and
- Diagonal dimensions are all correct BEFORE you start assembling the doorset.

**Fig. 1: Brickwork opening**

The required dimensions for the door frame:

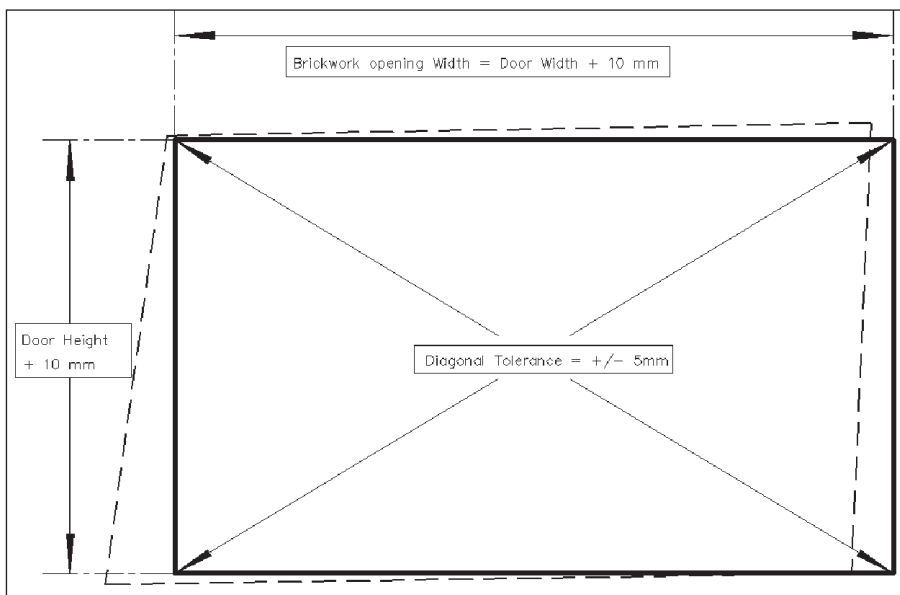

#### 2) Door Arrangements

You are supplied with a separate sheet, particular to your order, labelled '**Door & Hardware Arrangement Sheet**' that gives you complete installed view of all the door panels and hardware for your particular arrangement of Canberra Patio Doorset. If you have not received this sheet, you should contact JELD-WEN Technical on 01664 503453 and state the exact door arrangement for your doorset (for example 3000 wide door with 1L3R door arrangement). All the door panels on this sheet are shown in their correct position with the codes that corresponds to door panels codes supplied to you. You MUST make sure that you understand the correct position of all the door panels BEFORE you start the assembly.

#### 3) Hardware Arrangements

On the '**Door & Hardware Arrangement Sheet**' all the hardware is represented accurately positioned for your particular doorset. You MUST always follow these illustrations to put the Hardware on your door leaves. You should build the doorset by installing the door panels one-by-one. All the door panels are pre-drilled for exact position of the hinges/hardware. This also acts as a guide for you to choose the right hardware/door-panel at each stage. Please note that the hardware must NOT be put on all the doors at the same time.

## Fitting and Care Instructions for

Canberra and Wellington Patio Doorsets

### Section D

#### Installation

The assembly of your doorset is explained below in two phases. Phase 1 explains the assembly of the Outer Frame and its installation in the Brickwork opening. Phase 2 explains installing the door panels in to the Outer frame. You **MUST** follow these instructions for correct assembly of your doorset. Failure to do so may result in incorrect assembly and may damage your doorset.

#### Phase 1: Outer-Frame Assembly & Installation

##### Frame assembly

The Outer-Frame is supplied in four sub-assemblies. You must fix these together as explained below.

**Fig. 2:** Head Sub-assembly being fixed to the Jamb Sub-assemblies.



Fix both jambs to the Head section first. Screwfix the jamb assemblies to the head assembly by passing the 5 x 90 wood screws through the pre-drilled holes in the head assembly and securing these into the corresponding pilot holes at the top of the jambs. Ensure that the sealing gasket fills the joints between the components.

**Fig. 2a:** Installation ties secured to underside of sill

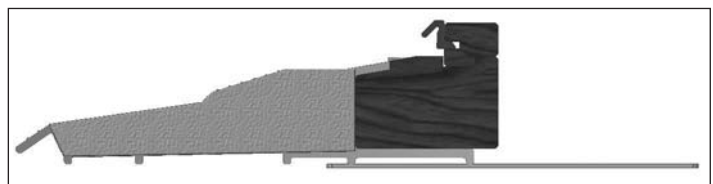
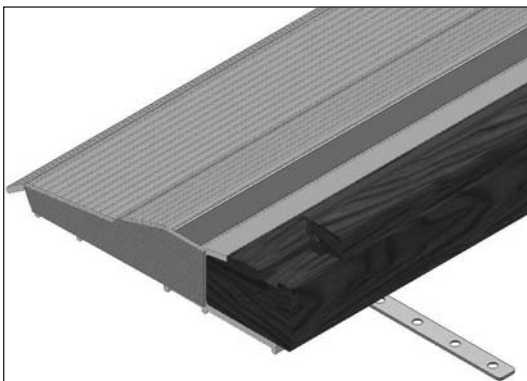

Fasten installation ties to the underside of the sill at the positions shown so that they will face the inside of the building.

# Fitting and Care Instructions for Canberra and Wellington Patio Doorsets

**Fig. 3:** Sill Sub-assembly being fixed to the Jambs, on both sides

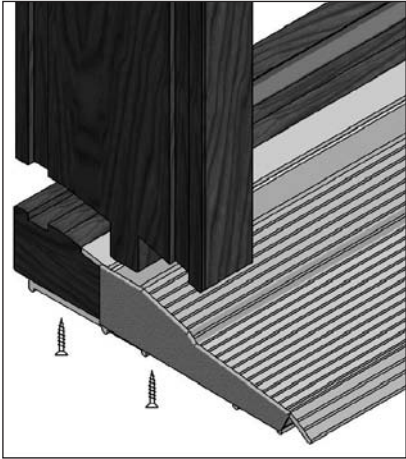

Screwfix the jamb assemblies to the sill assembly by fixing the 5 x 90 wood screws through the pre-drilled holes in the sill assembly and securing these into the corresponding pilot holes either side of the tenon at the bottom of the jambs. Ensure that the tenon on the bottom end of the jamb is correctly located into the channel in the sill and that the sealing gasket correctly fills the joint.

**Fig. 4:** Fully assembled Outer-Frame

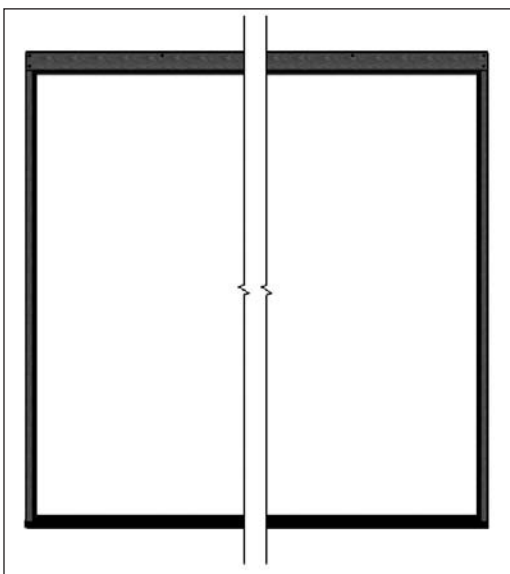
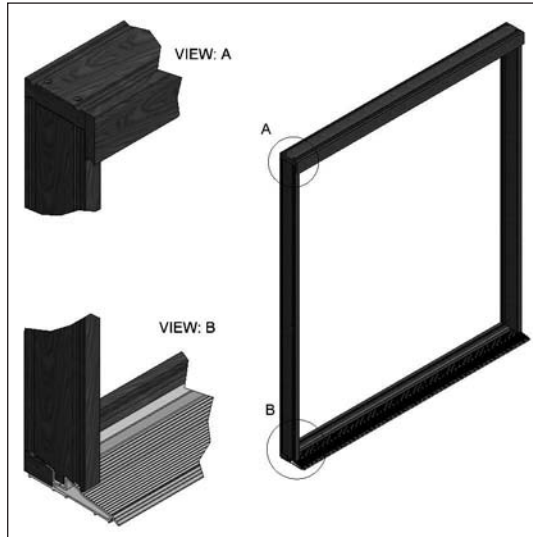

4(a) Front Elevation

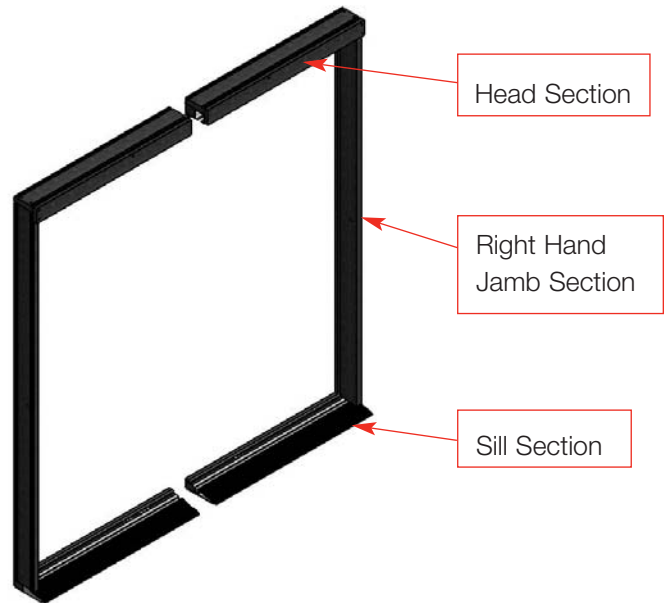

4(b) Isometric View

**At this stage you MUST make sure that all the sub-assemblies are fixed together tightly and the Outer frame is a perfect 'Square'. the diagonals of the Outer frame MUST also be equal (Tolerance +/- 5 mm). If the diagonals are not equal (within tolerances), you MUST NOT proceed to the next step.**

## Fitting and Care Instructions for

Canberra and Wellington Patio Doorsets

Place the assembled frame into the brickwork opening.

Adjust the position of the frame so that there is approximately 10mm of brickwork exposed in front of the jambs. The head track should be approximately in-line with the middle of the external flange of the lintel.

Place a 5mm packer at each end of the head, between the head and the lintel, above each jamb. For each end, lift the jamb so that the 5mm packer is tight between the head and the lintel and fit packers underneath the sill to hold this position.

Using a spirit level to check the level of the sill fit packers underneath the sill at the each fixing tie. If the lintel is not level it may be necessary to adjust the packers between the head and the lintel to ensure that the sill is installed level.

Ensure the jambs are vertical and not leaning forward or back and fit packers between the jamb and the brickwork at the top and bottom of each jamb.

Check that the diagonals of the frame are within 5mm. If they are not adjust the packing between the jambs and the brickwork until the frame is correctly square.

With the frame temporarily held in place by the packers, and ensuring that the frame is not knocked out of position, drill 8mm diameter holes 50mm into the brickwork through the prepared holes in the jambs.

Insert the frame fixing bolts through the jambs and into the holes in the brickwork and tighten them ensuring the jambs are not distorted and remain vertical.

For each of the sill ties locate a suitable fixing point on internal masonry and drill for a plug. Plug and screwfix each of the sill ties ensuring the sill is not distorted and remains level.

Before fixing the head to the lintel check again that the sill is level and the jambs are vertical, that there is no distortion in the jambs or the sill and that the diagonals of the frame are within 5mm of each other.

**Fig. 5: Fix the outer frame to the Brickwork**

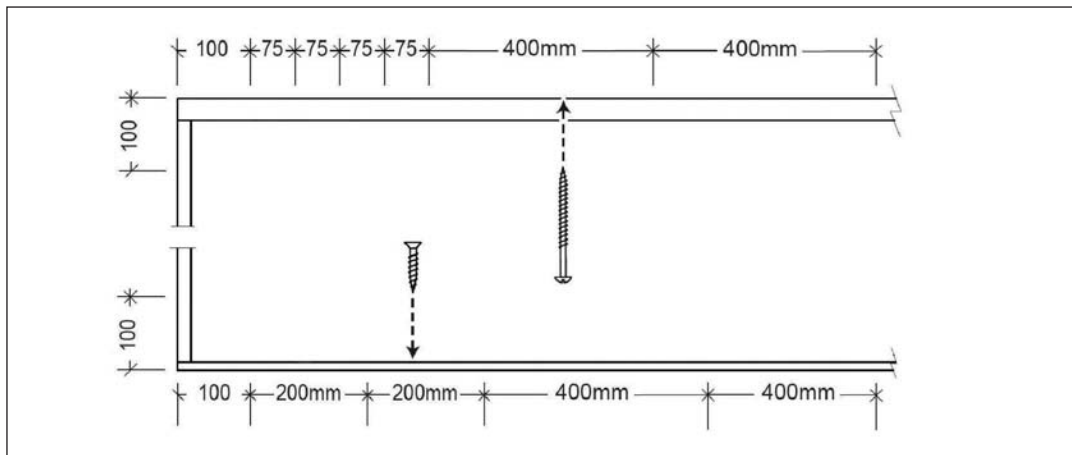

Fix the outer frame to the brickwork on All Four Sides according to the dimensions given above. On the Jamb sides, add further three fixing at equal distance of around 500 mm: Left hand end is shown above. Fix right hand end at same positions.

**Fig. 6: Method of fixing the Head Section to the Lintel**

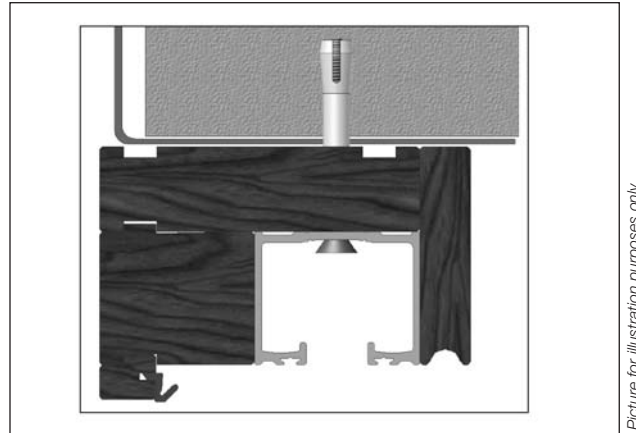

The Outer-Frame should now be overhanging the Cavity by approximately 45mm. This will allow the track fixings to be central to the external flange of a steel lintel (where used).

The fixings for the head pass through the predrilled holes and secured to the external flange of the lintel. They are self-drilling and tapping.

Apply a bead of silicone to each fixing before insertion. This will resist water tracking down the fixing screws onto the head of the doorset.

Starting with the two outer holes nearest the jambs, assemble a nylon washer onto the screw and pass the screw up through the head and screw into the lintel. Tighten the screw until it is just pulling tight. **DO NOT FULLY TIGHTEN AT THIS STAGE.**

At one of the middle fixing points, assemble and fit a screw and lightly tighten, pulling the head close to the lintel.

Working from the jambs towards the middle of the head fit and lightly tighten, the remaining screws while placing varying thicknesses of packers between the head and the lintel to create a slight upwards curve to the head ranging from approximately 5mm at each jamb (depending on the level of the lintel) to zero at the middle.

Once the correct curve on the head has been achieved tighten the fixing screws. **DO NOT OVER TIGHTEN.**

**Fig. 7: Bow in the Head Section of the Outer-Frame**

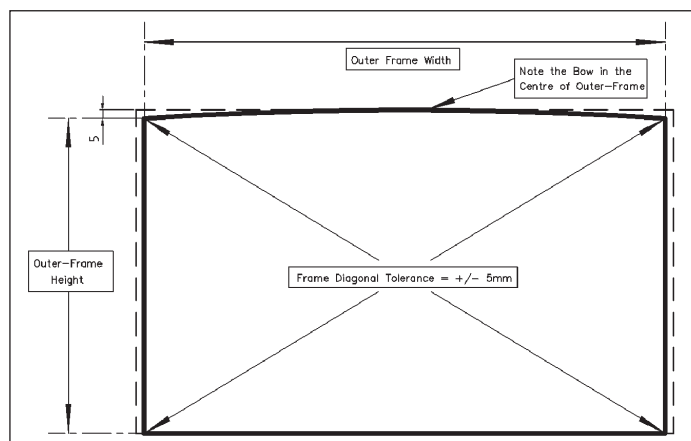

The 'Dotted' line represents the Brickwork and the 'Thick' line represents the Outer-Frame with a Bow of 5mm in the Head Section when correctly installed. This must be achieved by setting 5mm packers at the top of both jambs and then Centre of Head is screwed to the Lintel.

## Fitting and Care Instructions for

Canberra and Wellington Patio Doorsets

### Phase 2) Installing the door panels

All the door panels are supplied to you individually packed. They are coded and come with a sheet labelled **'Door & Hardware Arrangement Sheet'**. This sheet explains the correct position of the hardware and correct position of each door panel in the final assembly. While installing the door panels, you **MUST** refer to this sheet for their correct position.

**Fig. 8:** Prep the Top Channel in the Head Section of the Outer-Frame

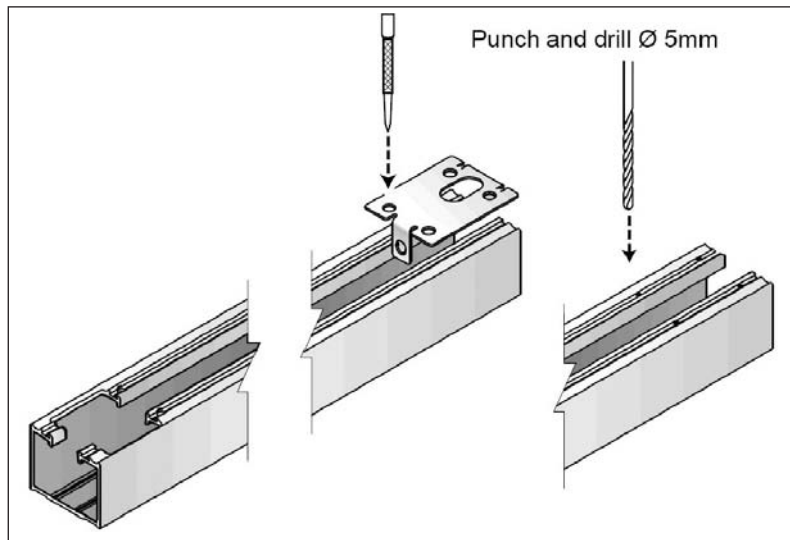

This channel is already fixed to the Head Section of the Outer-Frame. It is shown isolated only for ease of recognition.

### Fitting pivot hinges and carrier hinges

**Fig. 9:** Fitting top carriers and pivot hinges into head track

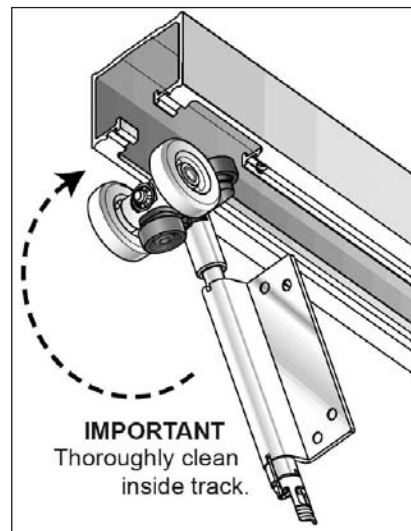

Install all the Hardware in the Top Channel of the Outer-Frame according to the arrangement of panels for your doorset. This is represented in the **"Door & Hardware Arrangement Sheet"** that accompanies this Instruction Manual.

When inserting the Top Pivot Block, it is important to ensure the Cover Plate is held clear and is loose.

# Fitting and Care Instructions for Canberra and Wellington Patio Doorsets

**Fig. 10: Top carriers and pivot hinge fitted to head track**

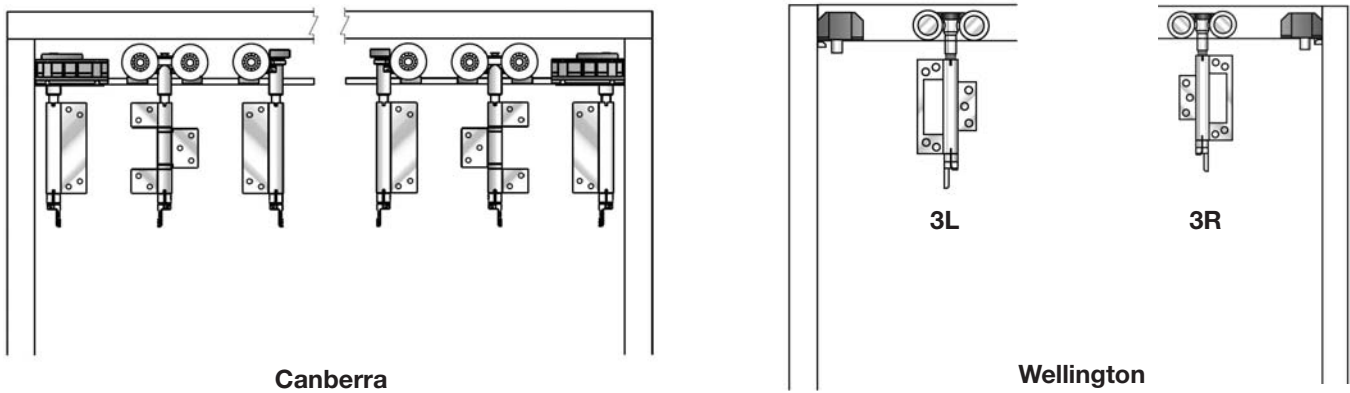

Depending upon the arrangement of the door panels in your door-set, you must insert all the hardware into the Top Channel in the correct order, before you start installing the Panels: You **MUST** refer to the **'Door & Hardware Arrangement Sheet'** for correct arrangement of Door Hardware.

**Fig. 11: Assembly of end carrier hinge**

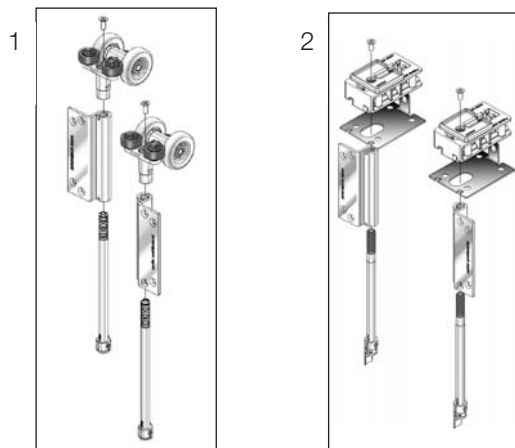

The End Carriers (as shown (1) above) and 'Top Pivot Blocks' (2) are 'reversible' assemblies and can be adjusted for 'Left' or 'Right' hand door panel.

**Fig. 12: Fixing and adjusting the top pivot block**

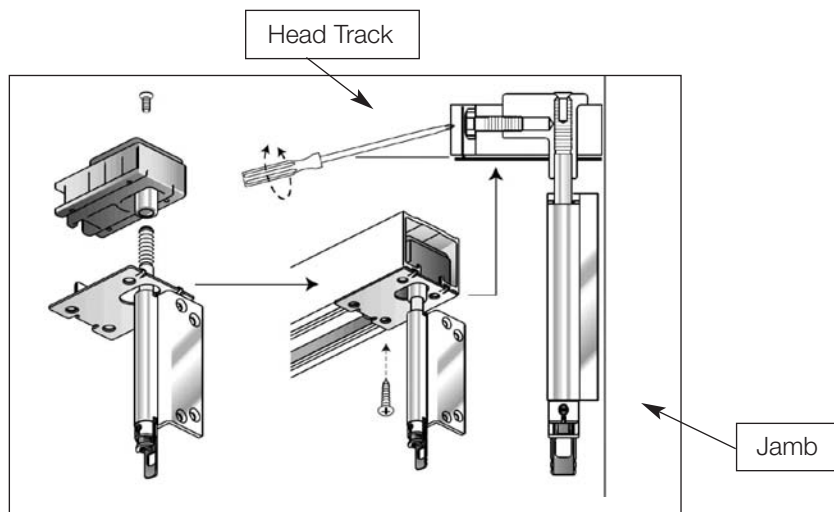

The top pivot block fit tightly against the jamb at the end of the head section.

## Fitting and Care Instructions for

Canberra and Wellington Patio Doorsets

**Fig. 13:** Fixing and adjusting the bottom pivot blocks

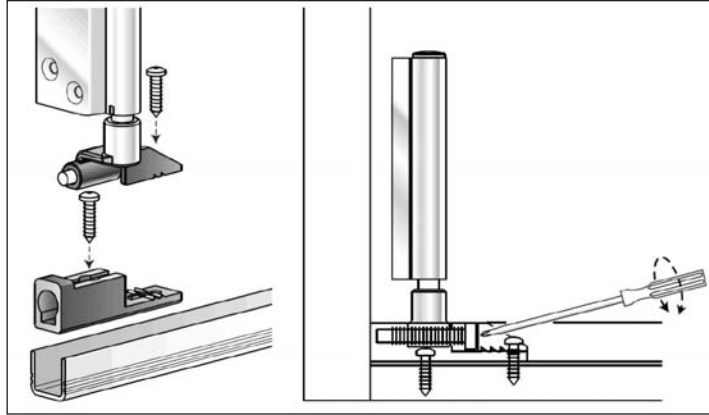

The bottom pivot blocks sit inside the sill channel and fit tightly against the jambs at each end of the sill.

## Hanging the door panels

**Fig. 14:** Installing First Door Panel to the Outer-Frame Assembly

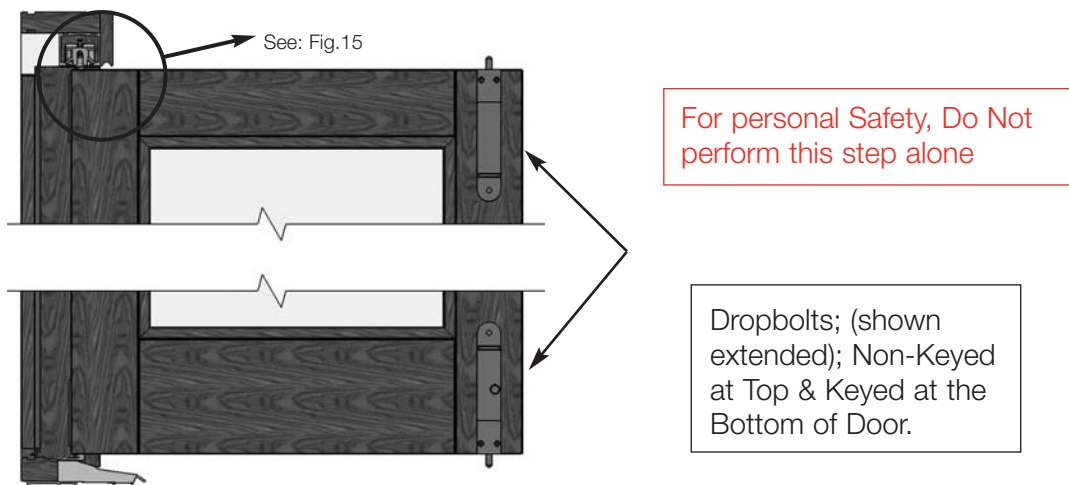

Leave the Dropbolts retracted.

**Fig. 15:** Fixing hinge plate of top pivot hinge



Fixing the first Door panel to the Top Pivot Block using prepared pilot holes on the Door.

You MUST adjust the length & position of the Weather-strip (Cut Between Hinges), when hanging the doors.

# Fitting and Care Instructions for Canberra and Wellington Patio Doorsets

**Fig. 16: Adjustment of top and bottom pivot hinges**

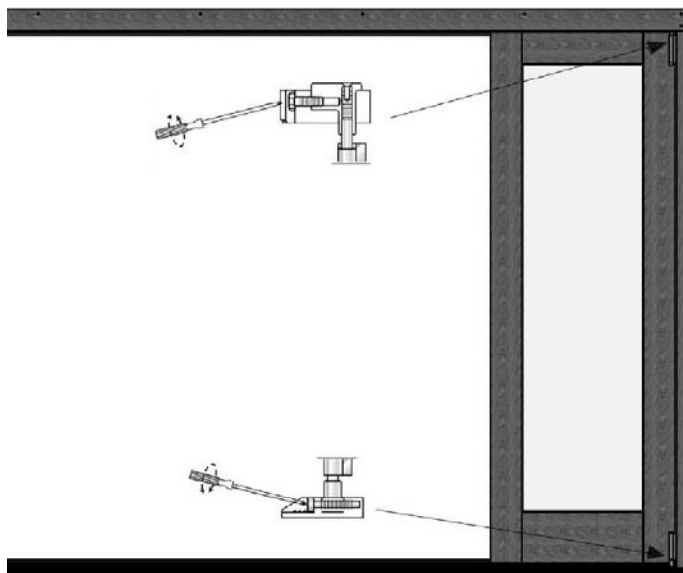

Top & Bottom Pivot Block Adjustment is necessary to set the door:

- a) perfectly vertical &
- b) for approx., 6 mm clearance between the Door and the Jamb.

(For all Clearances, see figures 18-21)

View from Outside: Adjust Top & Bottom Pivot Blocks BEFORE you continue adding further Door panels to the assembly.

**Fig. 17: Arrangement of door panels**

**Canberra only**

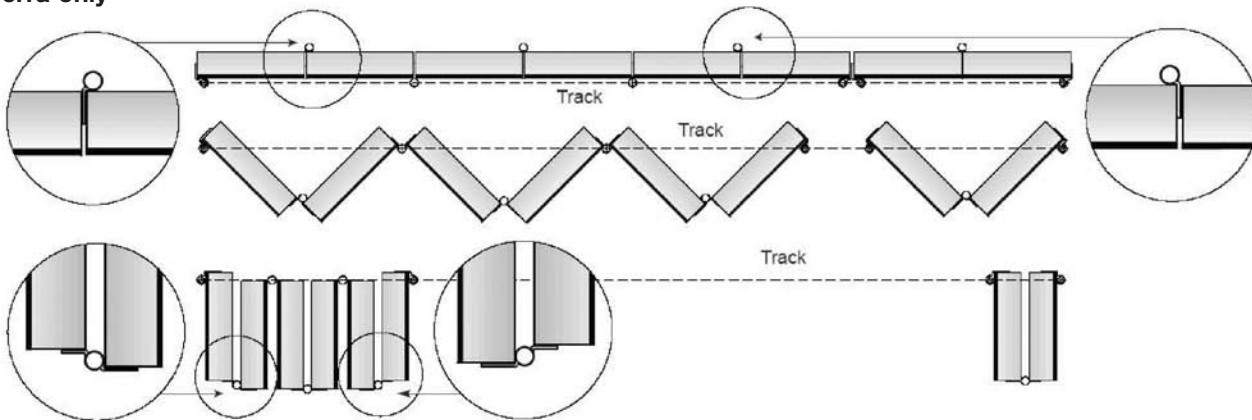

Now start adding further panels to the assembly. All the Door panels are pre-drilled for the correct position of the hinges. You MUST NOT drill any holes for the Hinges on the Door panels.

**Wellington only**

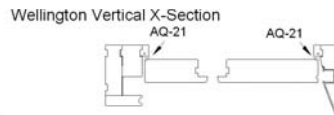
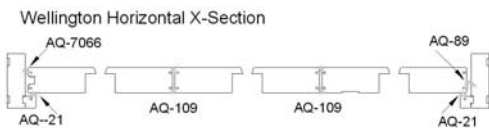

You MUST follow the illustrations on the **“Door & Hardware Arrangement Sheet”** for correct hardware to be used at the correct position on your door-set. Failing to do so will result in incorrect door assembly and may damage the Door panels.

## Fitting and Care Instructions for

Canberra and Wellington Patio Doorsets

**Fig. 18: Cross-sectional View from 'Top' :**

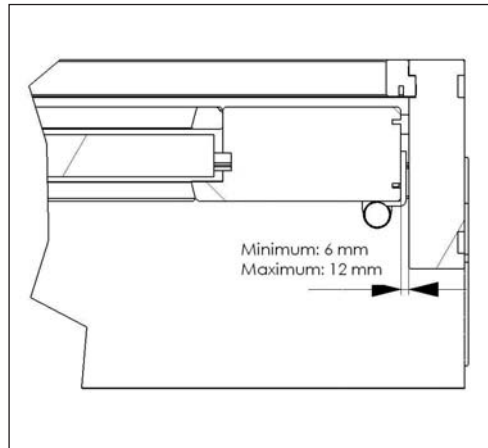

The dimension between the first door panel and the Jamb, when correctly installed, should be 6 mm prior to adjustment to give correct working clearance.

**Fig. 19: Cross-sectional View from 'Top':**

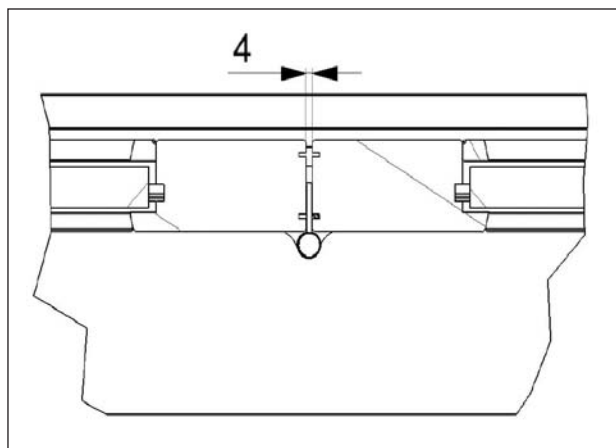

The dimension between any two door panels when installed should be 4 mm.

**Fig. 20: Cross-sectional View from 'Side':**

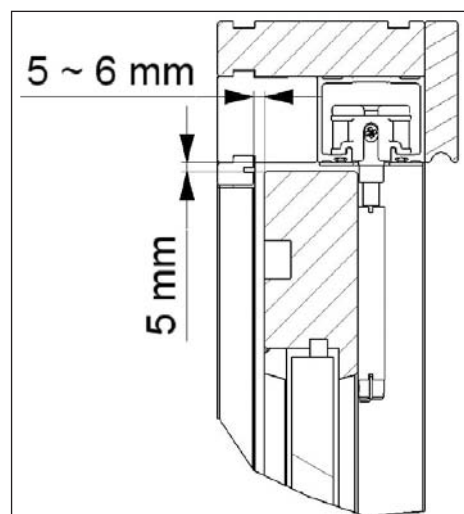

The clearance between the head track and the top rail of the door panel is 5mm. The clearance between the head stop and the door panel is between 5mm and 6mm.

**Fig. 21: Cross-sectional View from 'Side':**

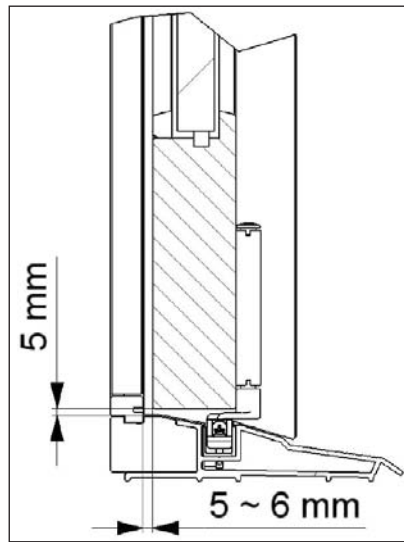

The clearance measured at the back (inside) of the sill rebate between the sill and the underside of the door panel is 5mm.

## **Adjustment**

Adjustments can be made to the top and bottom pivot hinges (next to the jambs) and to each carrier hinge located in the head track.

It is a principal of the Canberra and Wellington patio doorset that the greatest part of the door panel weight is taken by the carrier hinges and this is ensured by adjusting the end pivot hinges and the carrier hinges together.

The top and bottom pivot hinges can move a 'run' of hinged door panels a few millimetres left or right. This can be used to adjust the gap between a pair of 'meeting' door panels or to centralise all the door panels in the frame. Adjusting either the top or bottom pivot hinge separately can alter the angle of the first door panel and all panels hinged to it. This can take the load away from the top carrier hinges and these must then be adjusted to support the load once more.

The top carrier hinges can be adjusted up and down to raise or lower the door panels fixed to them or to ensure that the carriers continue to support the weight of the door panels if the end pivot hinges have been adjusted separately (see above).

If the frame is correctly installed then the clearances between pairs of door panels, door panels and the frame should be those given in the installation section.

## Fitting and Care Instructions for

Canberra and Wellington Patio Doorsets

### Finishing and maintenance

#### Finishing:

After finishing the installation of your doorset, check that all the fixings are secure and all the specified dimensions are achieved. It is vital for proper operation and long life of your Patio doorset.

#### Maintenance:

These products must be installed in accordance with accepted good trade practice (and in accordance with supplied instructions where applicable), and maintained in accordance with these procedures or else the warranty shall be void.

#### • Automatic Closers And Operators

All Door Hardware systems supplied are designed for manual operation only.

#### • Hardware

In buildings is subject to deterioration from everyday use, and also from environmental attack due to atmospheric and other conditions. Maintenance of hardware is even more important in severe environments such as coastal marine areas, and some industrial areas. Even stainless steel products require maintenance to prevent deterioration in some environments.

JELD-WEN UK Ltd requires the following minimum maintenance to be followed otherwise the warranty shall be void.

#### • Track And Bearings

Using a spatula or similar item (not your finger), apply a small amount (typically a 1/4 teaspoon) of white petroleum jelly (Vaseline) or similar lubricant to the inner lip of each side of the track. Ensure that the wheels pass through the lubricant and it is distributed evenly along the track. Put additional lubricant around bearings. Lubricant reduces wear, improves smoothness and further protects against corrosion of track and bearings. Remove all surface contaminants by wiping all visible track surfaces with a damp soft cloth and a mild detergent, then wipe clean with a clean cloth. In severe environments, apply a thin film of a corrosion preventative by wiping with a soft cloth moistened with one of corrosion preventative products.

Stainless-steel bearings are manufactured from hardening-grade stainless steel and although this material performs considerably better than plated steels, it is still susceptible to corrosion unless maintained as described above.

#### • Hangers, Pivots And Brackets

A light spray application of a corrosion preventative followed by a light wipe with a dry cloth to remove excess is recommended to all hangers, pivots and brackets. Exposed surfaces should first be wiped down with warm soapy water and a soft rag, and then rinsed clean before applying preventative.

#### • Hinges

Wipe down the visible surfaces with warm soapy water on a soft rag and then rinse off by wiping with a clean damp rag.

Application of a thin film of a light machine oil or one of the corrosion preventative sprays will help to maintain the original lustre of the metal finish. Be careful not to get these compounds on the timberwork itself as they may cause staining.

#### • Dropbolts

Spray application of a suitable lubricant to the sliding pin inside the bolt and to the lock cylinder is recommended. A tube attached to the nozzle will help to concentrate the spray where you want it to go. There are access holes or slots on all dropbolt products so that this can be done without removing the locks from the doors.

#### • Handles (Canberra only)

Canberra handle, are either Polished brass/Brushed brass or Polished Chrome/Aluminium Steel combination.

Refer to Hoppe leaflet in box. Polished solid brass is supplied as a natural, unlacquered finish. The finish can either be left to develop a naturally aged patina or polished with any commercial brass polish. **Wellington** handles are aluminium anodised.

#### • Frequency

The procedures mentioned above need to be carried out as often as is necessary to prevent deterioration in the installed environment, however we recommend the following minimum frequency of application:

- General environments 6 monthly
- Marine and industrial environments 3 monthly

Regular maintenance is required to all hardware, even stainless steel; otherwise the manufacturer's warranty may be voided.